



**X melt**<sup>®</sup>

**Controller XM-820.** Specialised for gluing patterns.  
Start at the push of a button.

## Foldout controller XM-820

The XM-820 controllers represent the ideal addition to the X melt® InterActive hotmelt units.

They allow path-related control of up to 8 hotmelt application guns even without external control (PLC). You can apply and repeat the same hotmelt tracks as often as desired on any packaging following the entry of the desired application patterns for all guns.

### Specialised for gluing patterns

The controller is installed ideally where you are gluing your products. You are not taking an extra step. You are always ready. You only need to carry out a few actions to enter a new pattern when starting a new order and you can see the results of your entries immediately in front of you. You can add or switch off individual guns easily.

The controllers work independently on one hand but are also strong in terms of communications.

They process external signals from light barriers, shaft encoders or other events. Two additional inputs and outputs take care of signal exchange with parent machines like alarm signals.

### XM-820

- Unglued products move towards the firmly mounted application guns
- Products are recognised and glued pathrelated can create two different successive glue tracks
- Uniform products therefore are glued, the same way every time
- Reproducible quality even at high production speeds of up to 200m/min. (656ft/min.)
- You only define the distance up to the front edge of the product to enter the desired glue track position
- The gluing pattern is applied ideally under consideration of the machine speed by automatic compensation

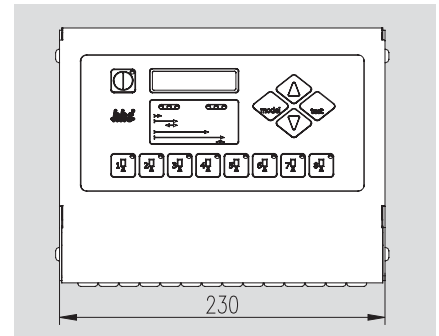
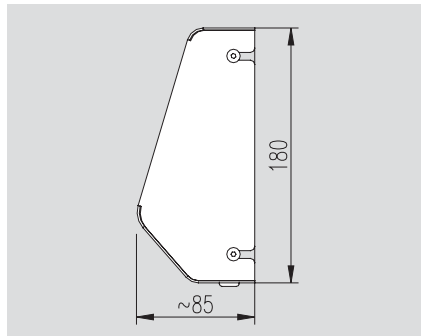

All specifications subject to change without prior notice.



### Technical data

Model	Supply voltage	Connected output	Fuse	Inputs	8 gun outputs	
XM-820	+24V ±10%	150 W	1 AT	4 Start inputs 1 Encoder input Signal voltage +24 V PNP	Control voltage +24 V Max. control current 1 A Max. charge from guns and additional outputs 6A	
2 additional inputs		2 additional outputs		Max. machine speed	Max. blank length	Glue tracks per channel
Control voltage +24 V		Control voltage +24 V Max. control current 0,5 A Max. charge from guns and additional outputs 6A		200 m/min. 656 ft/min.	4.000 mm 155 inch	2

Further information and product advantages can be found under [www.xmelt.com](http://www.xmelt.com)

 Baumer hhs

Baumer hhs GmbH

Adolf-Dembach-Straße 7 · 47829 Krefeld · Germany  
Phone +49 (0)2151 4402-0 · Fax +49 (0)2151 4402-111  
info.de@baumerhhs.com · www.baumerhhs.com